

---

**THE BLOCK BRAKING SYSTEM**  
**INSTRUCTION MANUAL**

**VERSION: A5**

**DATE: Dec., 2024**

# Contents

1. Tools .....	2
2. Installation of the brake .....	3
3. Adjustment of the stroke.....	4
4. Notice.....	5
5. Installation and debugging of the lever of the brake micro switch .....	7
6. Manual releasing device .....	10
7 Remote release device .....	11
8. Problems and solution of the brake.....	14
9. Maintenance of the brake.....	16

**NOTICE!!!** Before adjust the braking system should confirm the car's position to prevent strong tip and crouch driver of bottom.

**WARNING!** When the machine has load, do not adjust the two brakes at the same time.

**ATTENTION!** When adjusting the braking system, be sure that the one

#### Safe illustration:

[1] It is forbidden that non-professional persons operate the machine.

[2] Before installation, use and maintenance, read this instruction manual carefully, do as the manual says strictly, to avoid equipment damage or person hurt.

[3] Be cautious when operating, especially the elevator without the machine room, the operator is sure to stand on the safe site.

[4] The manual introduces some components adjustments, it is forbidden to adjust unaccounted components.

#### Working conditions:

[1] The ambient air temperature should be maintained between 5 and 40 ;

[2] The fluctuation of the supply voltage relative to the nominal voltage of the system should be within  $\pm 7\%$ ;

[3] Ensure that the friction surface is clean and not corroded by oil stains, rain, water, snow, etc.

### 1. Tools

16# open spanner ( two), feeler, cross screwdriver, 21# open spanner, multimeter,

noise meter, 0~80Nm torque spanner.

## 2. Installation of the brake

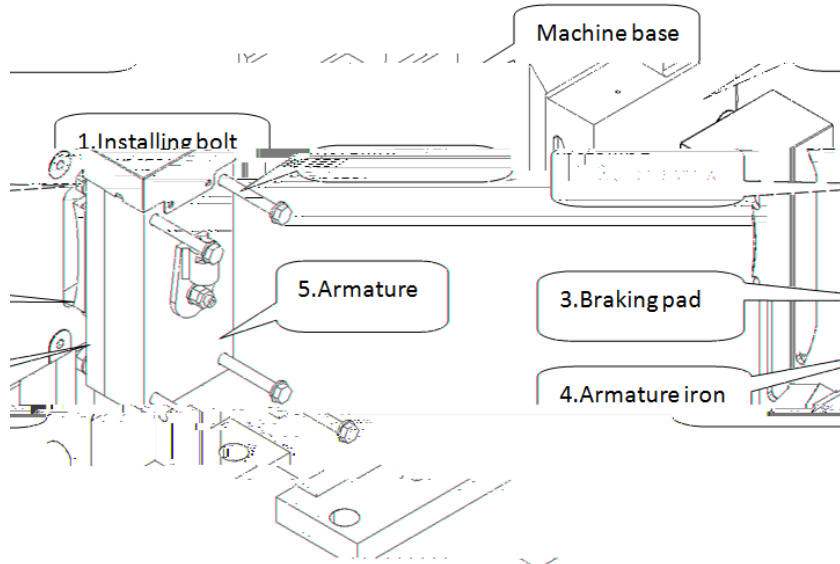

Fig. 1.1

Refer to fig.1.1, make part 1 installing bolt cross through part 5 armature, part 4 armature iron, part 2 guide screw and connect the brake with the machine base. When part 3 braking pad touch the braking wheel, tighten part 1 installing bolt, make part 2 guide screw surface depending on the machine base surface.

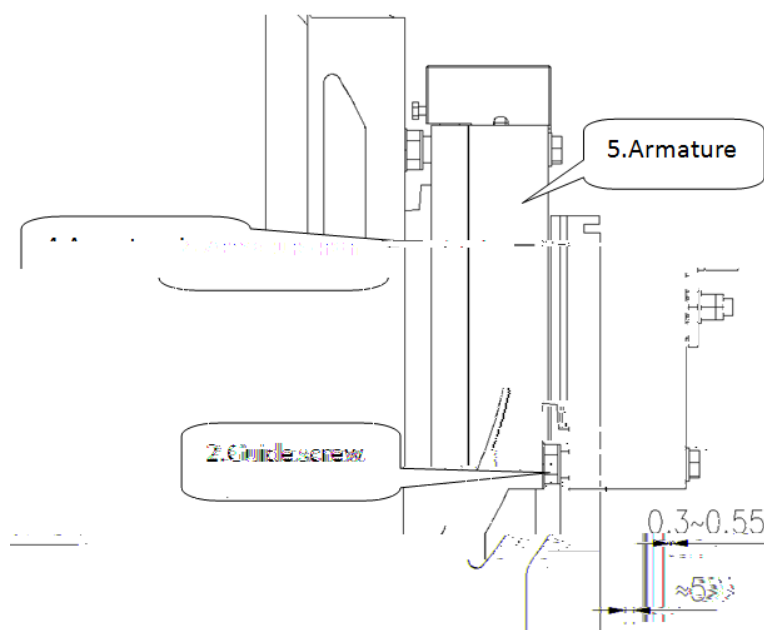

Fig. 1.2

Adjust part 2 guide screw and part 1 installing bolt, make the air gap between part 5 armature and part 4 armature iron is between 0.3~0.55mm, the gap between the braking pad and the braking wheel is between 0.11~0.19mm, the distance between part 2 guide screw and part 4 armature iron surface is 5mm (no less than 3mm under any condition), refer to fig.1.2.

### 3. Adjustment of the stroke

The air gap of brake corresponds to the gap between the braking pad and braking wheel, so the aim of adjust the air gap of brake is to adjust the gap between the braking pad and the braking wheel.

[1] When the air gap of brake is more than 0.3~0.55mm, please do as follows:

- a) Rotate 4 installing bolts counterclockwise with 21# open spanner until the guide screw can rotate. Refer to fig.1.3.
- b) Rotate 4 guide screws counterclockwise with the 21# open spanner and test the air gap of brake while adjusting until the air gap of brake is between 0.3~0.55mm. Refer to fig.1.4.

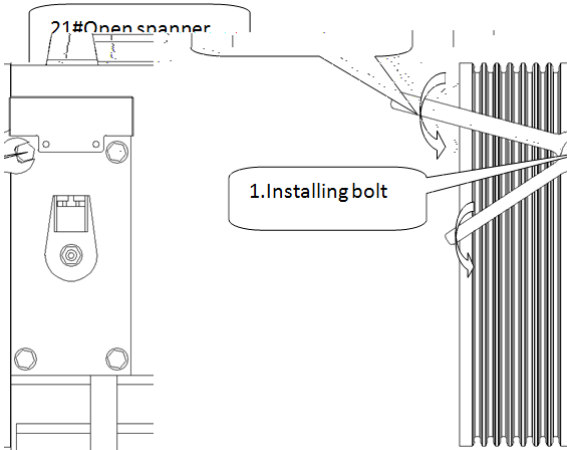

Fig. 1.3

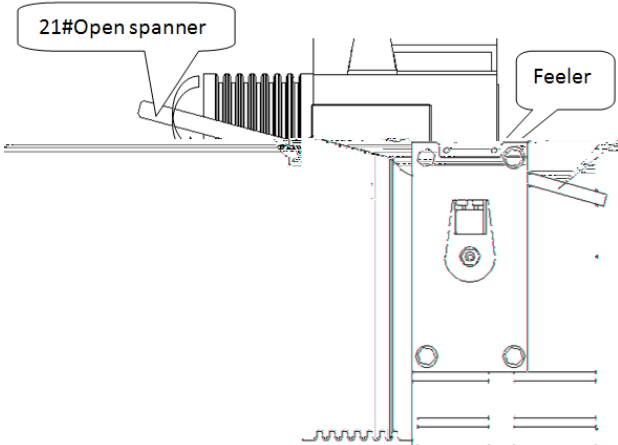

Fig. 1.4

- c) Rotate installing bolts clockwise, fix the brake and the machine base, make

the gap is between 0.30~0.55mm.

- d) Rotate 4 guide screws clockwise head to the center of base and make it depend on the base installing surface tightly. Refer to fig.1.5.
- e) The adjustment is over, check all the air gap of brake is within 0.3~0.55mm. If not, please readjust it according to step a ~ d.

[2] When the air gap of brake is less than 0.3~0.55mm, please do as follows:

- a) Rotate 4 installing bolts counterclockwise until the 0.3~0.55mm feeler can be put in.

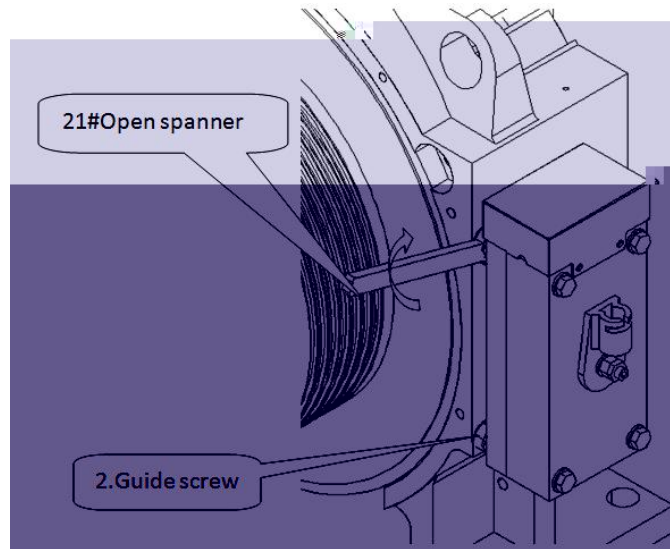

Fig. 1.5

- b) Rotate 4 guide screws clockwise head to the center of base and make it depend on the base installing surface tightly. Refer to fig. 1.5.
- c) Tighten 4 installing bolts clockwise until the 0.3~0.55mm feeler can be put out freely.
- d) The adjustment is over, check all the air gap of brake is within 0.3~0.55mm. If not, please readjust it according to step a ~ c.

#### 4. Notice

[1] When adjust the bolts, you should adjust it diagonally. The four angles air gap

difference between armature and armature iron evenly as possible.

[2] When the adjustment is over, tighten 4 installing bolts with torque spanner and make the four guide screws depend on the base installing surface tightly. Every bolt and guide screw must be 80N.m lock condition.

[3] When adjusting the bolts, the adjust range must be as small as possible. The air gap of brake will change 0.1 mm for rotate guide screw 30 degrees.

[4] Please adjust the two brakes separately.

[5] You'd better not adjust the lock nuts at the releasing bolt. If it is necessary, please note the following points.

Refer to fig.1.6, it is easy to rotate the spanner at the first 0 ~15 degree. *(The 15 ° is about opening spanner is vertical arranged on the brake, forward or backward free swing angle)* It means that the spanner has about 15 degrees idle stroke and this time only need overcome back spring force. When the angle is more than 15 degree, it needs about 400N force to open the brake. If it is hard to open the brake at the first, please rotate the nut M10 counterclockwise and make it move about 1mm outward, And then use the outside of the Nut M10 thin nut to lock. Check if it is easy at the first 15 degree and make sure the manual releasing is useful.

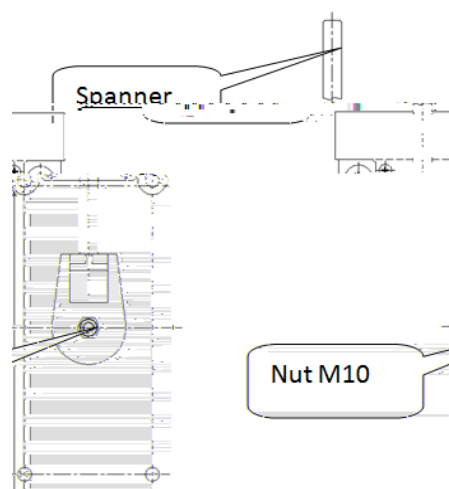

Fig.1.6

[6] When the adjustment is over, you should do test to check the braking force (such as the elevator static load test), lock all the adjusting points, make corresponding markers before put into operation.

## **5. Debugging and precautions of brake micro switch**

## [2] Problems and solution

- 1) The bolt worn make the lever stroke is not enough and the micro switch does not work.

Loosen the nut M5 of the locking bolt, rotate the bolt, and move it slightly towards the micro switch side. Each adjustment should not exceed 0.1mm, and the maximum stroke of the bolt should not exceed 0.3mm, otherwise the micro switch will not work properly. After adjusting the travel, tighten the nut, power on the brake, and check whether the micro switch operates reliably (repeatedly check 3-4 times). After ensuring that the switch operates reliably, tighten the nut again.

- 2) The bolt stroke is too long and the micro switch can not reset.

Loosen the nut M5 of the top rod bolt, rotate the bolt slightly backwards, then lock the nut M5, power on the brake, check whether the micro switch is reliably operated, and repeat the check 3-4 times to ensure that the micro switch is reliably operated before locking the nut M5.

- 3) The brake switch lever mechanism should be regularly maintained, and special attention should be paid to whether the micro switch lever is in normal working condition.

## **Installation and debugging of the lever of**

Fig.1.7 a

#### [1] Adjustment

A micro switch support with a leaf spring and a micro switch is installed on the armature. By adjusting the position of the bolt to change the stroke in order to ensure the micro switch working reliably.

#### [2] Problems and solution

- 1) The bolt worn make the lever stroke is not enough and the micro switch does not work.

Loosen the nut M5, rotate the bolt towards the leaf spring a little, each adjustment should less than 0.1mm, or the leaf spring will be deformed. The Bolt should less than 0.5mm, or the micro switch cannot work properly. After the stroke is adjusted, The Nut M5 is tightened, Connect the brake to the power and check whether the stroke switch is reliable

3-4 times, make sure that the micro switch is useful, then lock the nut M5.

3) The brake lever device must be regular maintenance every year, especially the state of leaf spring, deal with timely if there is any problem.

## 6. Manual releasing device

When there are problems while the elevator running or the persons are kept in the car for the power off, you may use manual releasing device to operate.

NOTICE: The manual releasing device should be operated by 2 professionals, and make sure the power is shut down first.

Method to use the manual releasing device:

[1] One person use spanner of carrying machine respectively inserted into the left and right brake keyway and then rotary spanner. Make the pin on the spanner is just placed on the keyway To prevent the spanner slipping when manual releasing device . Then rotate and move spanner with force, the brake can be opened

[2] The steps of operation at the same time, another person take the handwheel down from the wall, fix the small gear on the machine, make the small gear engage with the big gear, rotate the handwheel to make the car move slowly.

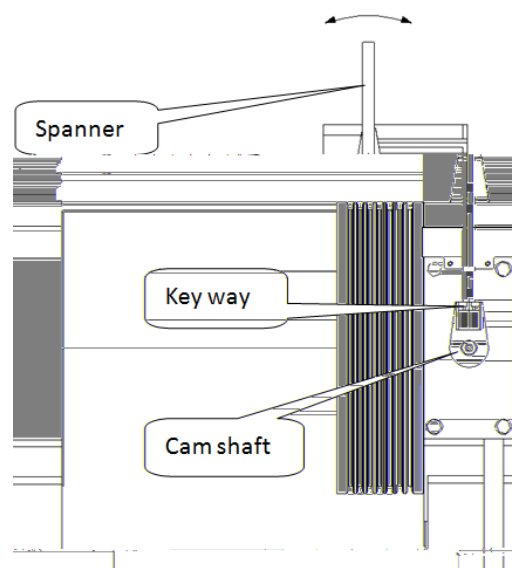

Fig.1.8

## 7 Remote release device

When the elevator is installed without the machine room, it is necessary to use the remote release device for emergency operation when the elevator is in the process of operation, or because of power failure caused by the situation.

**Note:** The handle should be installed in a safe location, can only be operated by professional personnel, ensure the operation cut off the main power supply, to strictly prevent the brake opened causes the elevator to slip danger.

When installing a remote release device, the brake shall not be adjusted without permission;

Remote release device has been adjusted, no special circumstances do not adjustment have fixed on the brake device of the machine.

[1]Remote release device and the main parts

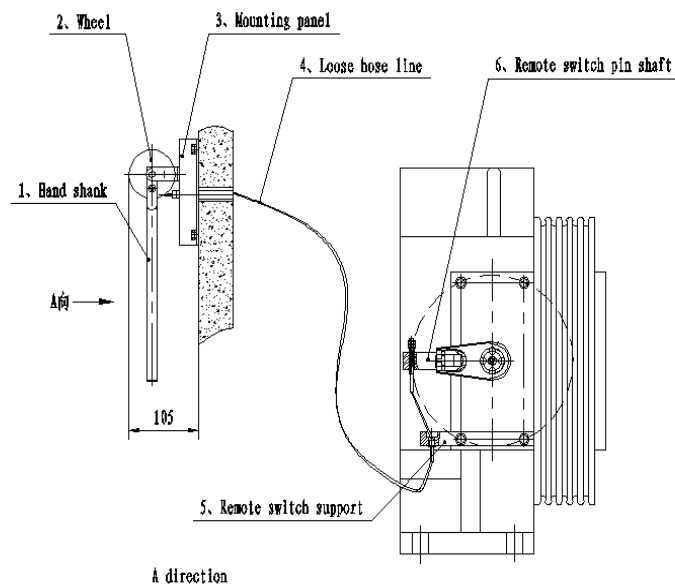

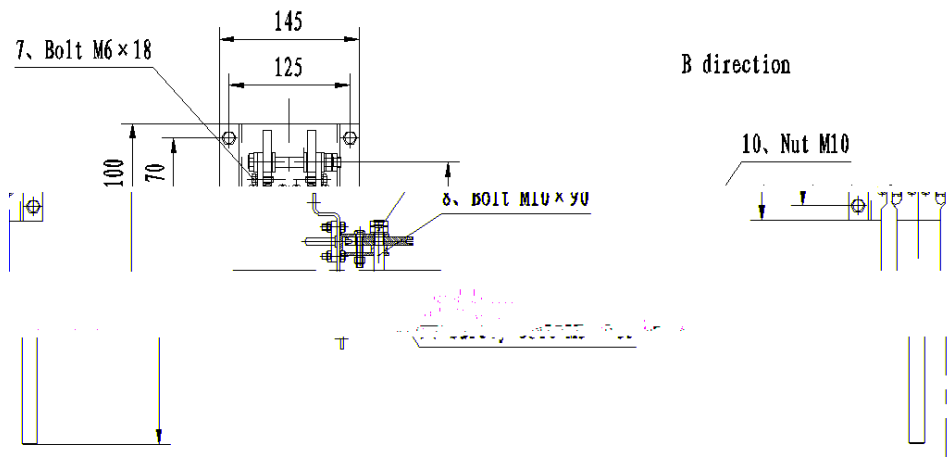

Fig.1.9

[2]The remote release device profile

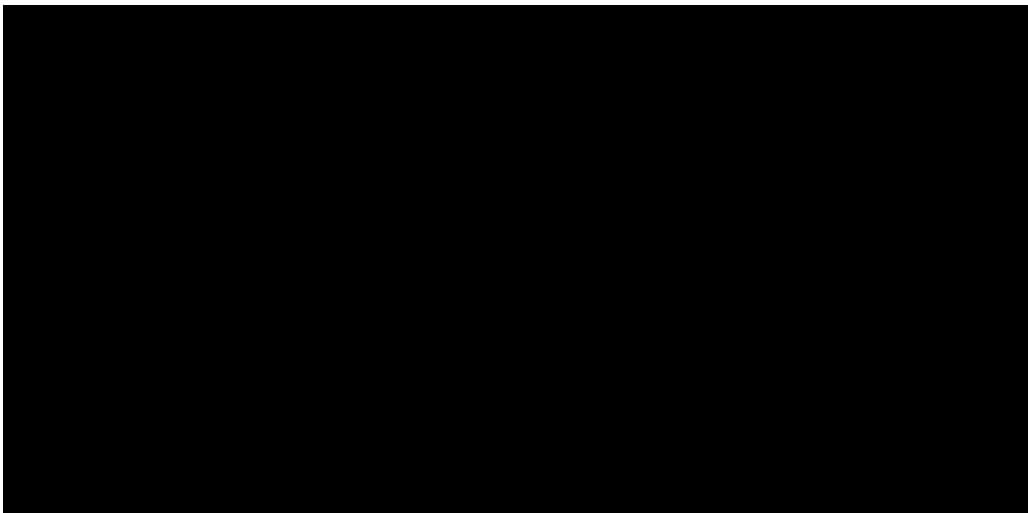

Fig.1.10

[3]The installation of remote release device

1)The two loose hose lines 4 are respectively passed through the traverse holes of the mounting plate 3 and are respectively mounted on wheel 2 which has been fixed to the mounting plate. The relative position of wheel 2 and handle 1 when installed as shown in fig. 1.10 ensures that wheel 2 is inside the handle 1, Only in this way can the rope slot on wheel 2 correspond to the crossing hole of mounting plate 3. After installing the loose gate hose line 4, lock wheel 2 and handle 1 with the bolt of M6× 20;

- 2)The other end of the two loose hose lines 4 is passed through the remote switch bracket 5, which has been fixed on the brake, and the remote switch pin shaft 6 is inserted into the cam mounting hole of the brake and rotates 45 degrees, the long distance opening pin shaft 6 is inserted into the cam mounting hole of the brake, and the long distance switch pin shaft 6 is inserted into the cam mounting hole of the brake. Prevent remote opening pin shaft from falling off, then use locking nut to pre-tighten the stud of the 4 head of the hose line 4.
- 3)The mounting plate 3 is reliably fixed in the control cabinet or installed in a lock cabinet with sufficient space;
- 4)After installing the remote release gate, debug according to the "4, remote release device debugging instructions".

[4]

causing the running of the car, etc.

[5] The use of remote brake device

- 1) Take down the safety bolt M6\*35 of the serial number 9, and raise two handle 1 at the same time. The handle 1 rotates about 105 degrees and two brakes will open, when the sluice is loosened, the speed of the car and the flat layer of the car will be paid attention to, and the flat layer completes the opening of the handle immediately and stops the sluice.
- 2) All parts must be reset after the remote release operation and handle 1 is restored to its original position.

[6] Notes

- 1) When the soft pipeline is arrangement, the radius of the line is more than 500mm, In order to avoid the cable bending too big movement is not flexible;
- 2) After assembly must be tested several times to ensure the movement of the device flexible Automatic reset If there is a problem, the connection must be adjusted to meet the requirements Otherwise prohibit the use of.

## 8. Problems and solution of the brake

[1] The braking pad rubs the braking wheel, the machine working with the brake. (The gap between braking pad and braking wheel should be between 0.11 ~ 0.19mm.)

- 1) Test measure
  - a) Hear the sound. If there is friction between them, you can listen hissing sound.
  - b) Observe if there is bright friction trace on the braking wheel surface. The braking wheel will be hot when the friction is serious.
  - c) Insert a 0.1mm feeler between the braking pad and the braking wheel and move it back and forth along the circumference, check if the feeler can go

through the air gap between the braking pad and the braking wheel.

## 2) Solution

- a) Check if the guide screw depend on the machine base surface tightly. If not, please rotate the guide screw clockwise by 21# open spanner and make it depend on the base surface tightly. Refer to fig.1.5.
- b) If the guide screw has already depend on the machine base surface tightly, please loosen the four installing bolts counterclockwise, then rotate the guide screw clockwise and make it depend on the machine base surface tightly, at last, lock the four installing bolts with torque spanner. Refer to fig.1.5.

## [2] Brake can't work

- a) Low input voltage. Check if the input voltage exceeds the 80% of the rated voltage. If not, increase the input voltage properly.
- b) The air gap of the brake is more than 0.55mm. If it is, adjust it as Described above.

## [3] Brake noise exceeding standard

1 The noise of brake opening exceeds the standard. The countermeasures are as follows:

(a) check whether the air gap of the brake is within the prescribed range of 0.3 -0.55 mm and, if it is out of range, adjust the air gap in accordance with the preceding "three air gap adjustments";

b if the shock absorber is seriously worn and flush with the armature suction surface, contact the brake manufacturer for replacement if the wear is severe.

2) the noise released by brake exceeds the standard

This situation is mainly due to the larger gap between the brake belt and the brake wheel. According to the contents of "3. air gap adjustment" in front of the brake, the air gap of the brake is adjusted, and the gap between the brake belt and the brake wheel is reduced. The noise released by brake can be reduced (gap between

brake belt and brake wheel requires 0.11~0.19mm).

[4] Micro switch trigger fault

According to the previous content "5. brake micro switch installation and debugging and matters needing attention" in article 2 of the explanation.

## **9. Maintenance of the brake**

When the braking pad has a little worn, it would add the brake air gap and make the braking noise much bigger. You may adjust it .When there is much worn of it, the brake would not work. When its thickness is less than 5mm, replace it.

NOTICE! The static load test method: add 150% rated load in the car, observe the braking wheel for ten minutes, there should have no skid between the braking wheel and the braking pad.

WARNING! If the braking force test is unqualified, then the elevator is forbidden to be electrified, otherwise it would occur accidents.